

# TH CDLF

## STAINLESS BOOSTERS



### General Information

High pressure, quiet running, compact and low power consumption.  
 All surfaces that contact with the liquid are stainless steel, In-line (straight pipe attachable) type pumps.  
 CDLF pumps are suitable for pumping non-abrasive, clean or slightly contaminated, low-viscosity liquids without solid & fibrous particles.  
 Bearing is provided by tungsten carbide sliding bearings.  
 Vertical structure saves space.

### Technical Data

Capacity \_\_\_\_\_ up to 110 m<sup>3</sup>/h  
 Head \_\_\_\_\_ up to 160 m  
 Operating Temperature \_\_\_\_\_ -10 °C to 120 °C  
 Casing Pressure \_\_\_\_\_ 10 - 16 - 25 bar

- Electric motors of high efficiency class conforming to IEC 60034-30 standard are used.
- Booster pumps can be manufactured with valve, check-valve, stainless steel base plate, depending on request.
- The booster pumps can be manufactured as a variable-speed frequency control for convenience.
- At 11 kW and above, the booster pump base plate is NPU iron construction.

### Design Features

- TH CDLF booster pumps are manufactured as vertical pump.
- The booster pumps are produced as single, double and triple pumps as a standard according to the desired flow rate. Upon request, up to 6 pumps can be set.
- For Single-pump booster pumps have a water level float (electric floater).
- Phase control system (PCS) is available in single pump, three-phase motorized booster pumps.
- Sequencing, phase control and liquid level control are standard features for multiple pumped booster pumps.
- Booster pumps can operate in two different modes; automatically and manually.
- Electrical materials used in the booster pump panels are selected from reliable and quality brands.

### Material Information

Part Name	Material	
	Standard	Optional
<b>Pump</b>		
Base Plate	GG 25	-
Stage Casing	AISI 304	-
Intermediate Stage	AISI 304	-
Impeller	AISI 304	-
Shaft	AISI 304	-
Tube	AISI 304	-
Panel	Pressure Switch Controlled	Frequency Controlled
Collector	AISI 304	AISI 316 L / Galvanized Steel
Frame	Galvanized Steel	AISI 316 L
<b>Accessories</b>		
Valve	Brass	AISI 304
Check Valve	Brass	AISI 316

### Booster Designation

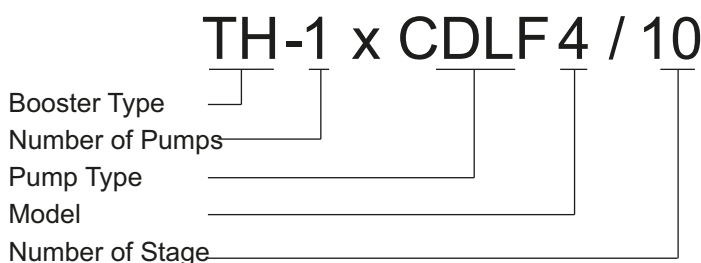

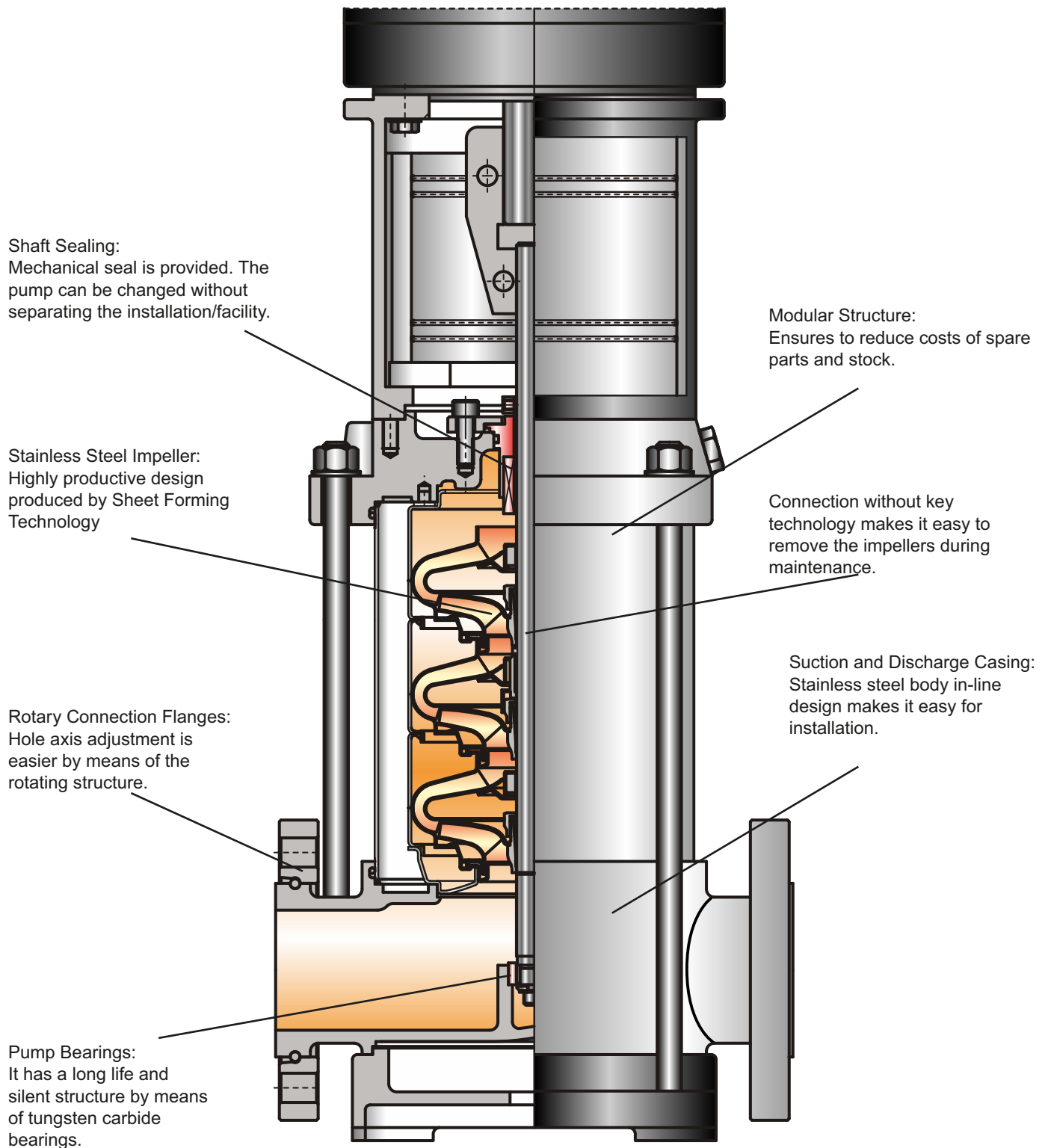

CDLF 4,8,12,16,20

CDLF 32,42,65,85

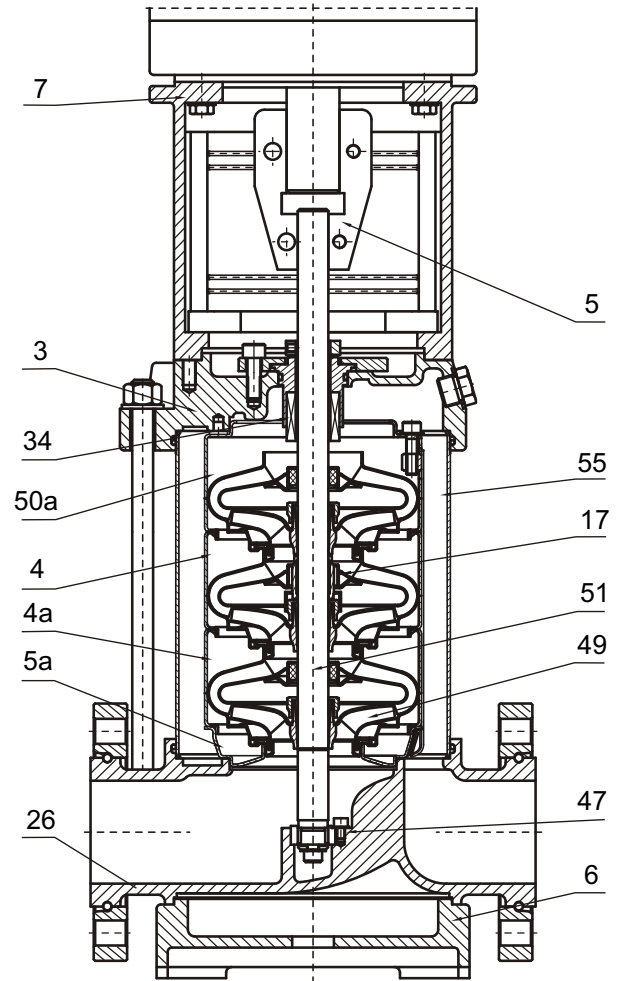
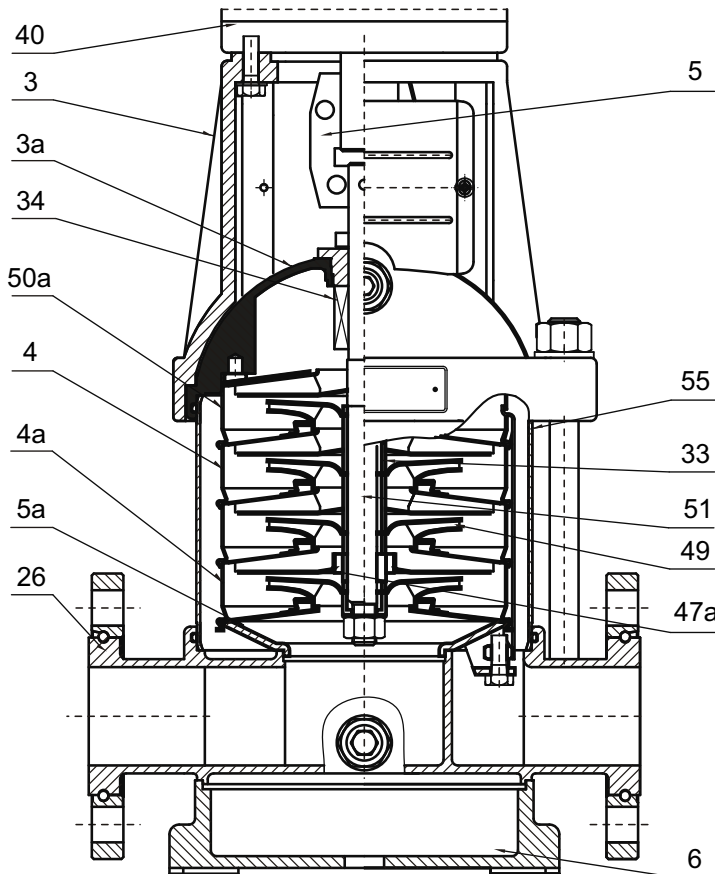

Part List

3	Upper Body	Cast Iron (GG 25)
3a	Liner	Stainless Steel (AISI 304)
4	Diuser	Stainless Steel (AISI 304)
4a	Lower Diuser	Stainless Steel (AISI 304)
5	Coupling	Carbon Steel
5a	Inducer	Stainless Steel (AISI 304)
6	Baseplate	Cast Iron (GG 25)
26	Suction and Discharge Casing	Stainless Steel (AISI 304)
33	Sleeve	Stainless Steel (AISI 304)
34	Mechanical Seal	-
40	Electric Motor	-
47a	Bearing	Tungsten carbide
49	Impeller	Stainless Steel (AISI 304)
50a	Upper Diuser	Stainless Steel (AISI 304)
51	Pump Shaft	Stainless Steel (AISI 304)
55	Cover Plate	Stainless Steel (AISI 304)

3	Upper Body	Stainless steel (AISI 304)
4	Diuser	Stainless steel (AISI 304)
4a	Lower Diuser	Stainless steel (AISI 304)
5	Coupling	Carbon Steel
5a	Inducer	Stainless steel (AISI 304)
6	Baseplate	Cast Iron (GG 25)
7	Motor Pedestal	Cast Iron (GG 25)
17	Bearing	Tungsten carbide
26	Suction and Discharge Casing	Stainless steel (AISI 304)
34	Mechanical Seal	-
47	Lower Bearing	Tungsten Carbide
49	Impeller	Stainless steel (AISI 304)
50a	Upper Diuser	Stainless steel (AISI 304)
51	Pump shaft	Stainless steel (AISI 304)
55	Cover Plate	Stainless steel (AISI 304)

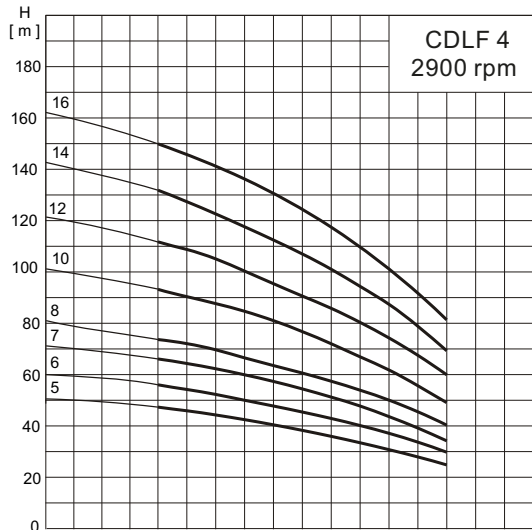

1 Pump	0.0	1.0	2.0	3.0	4.0	5.0	6.0	7.0	Q [m³/h]
2 Pump	0.0	2.0	4.0	6.0	8.0	10.0	12.0	14.0	Q [m³/h]
3 Pump	0.0	3.0	6.0	9.0	12.0	15.0	18.0	21.0	Q [m³/h]

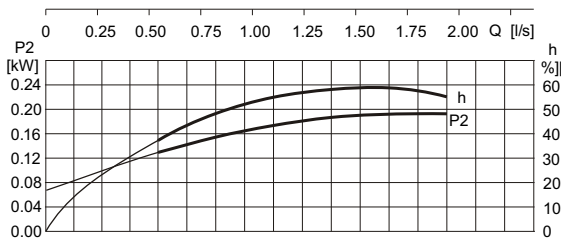

Performance curves are given according to ISO9906: 2012 Gr3B.

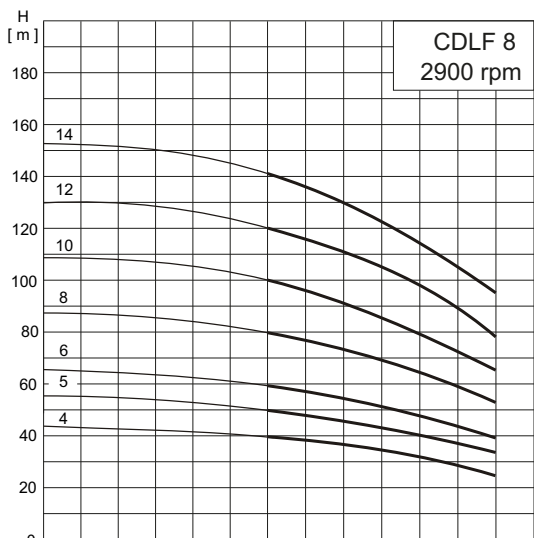

1 Pump	0	2	4	6	8	10	Q [m³/h]
2 Pump	0	4	8	12	16	20	Q [m³/h]
3 Pump	0	6	12	18	24	30	Q [m³/h]

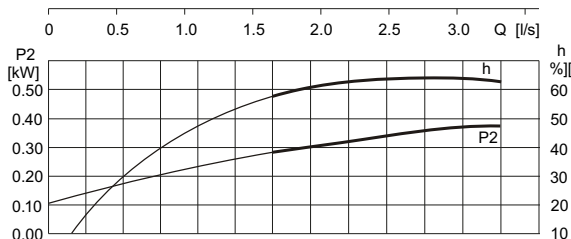

Performance curves are given according to ISO9906: 2012 Gr3B.

Pump Type	De	Db	Ba	Bb	Ba(max)	H	Ka	Kb	E	A	Tas.	w	
TH-1xCDF 4-5	1,1	1 1/2"	1 1/4"	400	300	450	700	320	280	415	125	A	39
TH-1xCDF 4-6							700						39
TH-1xCDF 4-7	1,5	1 1/2"	1 1/4"	400	300	450	800	320	280	415	125	A	45
TH-1xCDF 4-8							800						45
TH-1xCDF 4-10	2,2	1 1/2"	1 1/4"	400	300	450	900	320	280	415	125	A	49
TH-1xCDF 4-12							950						50
TH-1xCDF 4-14	3	1 1/2"	1 1/4"	400	300	450	1000	320	280	415	125	A	58
TH-1xCDF 4-16							1050						60

Pump Type	kW	De	Db	Ba	Bb	Ba(max)	H	Ka	Kb	E	A	Tas.	w
TH-2xCDF 4-5	1,1	2"	2"	1000	400	1150	700	670	380	587	125	A	101
TH-2xCDF 4-6							700						101
TH-2xCDF 4-7	1,5	2"	2"	1000	400	1150	800	670	380	587	125	A	113
TH-2xCDF 4-8							800						113
TH-2xCDF 4-10	2,2	2"	2"	1000	400	1150	900	670	380	587	125	A	121
TH-2xCDF 4-12							950						123
TH-2xCDF 4-14	3	2"	2"	1000	400	1150	1000	670	380	587	125	A	139
TH-2xCDF 4-16							1050						143

Pump Type	kW	De	Db	Ba	Bb	Ba(max)	H	Ka	Kb	E	A	Tas.	w
TH-3xCDF 4-5	1,1	2"	2"	1000	400	1150	700	920	380	587	125	A	147
TH-3xCDF 4-6							700						147
TH-3xCDF 4-7	1,5	2"	2"	1000	400	1150	800	920	380	587	125	A	165
TH-3xCDF 4-8							800						165
TH-3xCDF 4-10	2,2	2"	2"	1000	400	1150	900	920	380	587	125	A	177
TH-3xCDF 4-12							950						180
TH-3xCDF 4-14	3	2"	2"	1000	400	1150	1000	920	380	587	125	A	204
TH-3xCDF 4-16							1050						210

Pump Type	kW	De	Db	Ba	Bb	Ba(max)	H	Ka	Kb	E	A	Tas.	w
TH-1xCDF 8-4	1,5	2"	1 1/2"	450	400	500	800	370	380	465	130	A	54
TH-1xCDF 8-5	2,2						800						58
TH-1xCDF 8-6	3	2"	1 1/2"	450	400	500	850	370	380	465	130	A	59
TH-1xCDF 8-8							950						67
TH-1xCDF 8-10	4	2"	1 1/2"	450	400	500	1000	370	380	465	130	A	78
TH-1xCDF 8-12							1100						80
TH-1xCDF 8-14	5,5	2"	1 1/2"	450	400	500	1250	370	380	465	130	A	95

Pump Type	kW	De	Db	Ba	Bb	Ba(max)	H	Ka	Kb	E	A	Tas.	w
TH-2xCDF 8-4	1,5	2"	2"	920	450	1100	800	840	430	665	130	A	131
TH-2xCDF 8-5	2,2						800						139
TH-2xCDF 8-6	3	2"	2"	920	450	1100	850	840	430	665	130	A	141
TH-2xCDF 8-8							950						157
TH-2xCDF 8-10	4	2"	2"	920	450	1100	1000	840	430	665	130	A	179
TH-2xCDF 8-12							1100						183
TH-2xCDF 8-14	5,5	2"	2"	920	450	1100	1250	840	430	665	130	A	213

Pump Type	kW	De	Db	Ba	Bb	Ba(max)	H	Ka	Kb	E	A	Tas.	w
TH-3xCDF 8-4	1,5	2 1/2"	2 1/2"	1300	450	1500	800	1220	430	680	130	A	190
TH-3xCDF 8-5	2,2						800						202
TH-3xCDF 8-6	3	2 1/2"	2 1/2"	1300	450	1500	850	1220	430	680	130	A	205
TH-3xCDF 8-8							950						229
TH-3xCDF 8-10	4	2 1/2"	2 1/2"	1300	450	1500	1000	1220	430	680	130	A	262
TH-3xCDF 8-12							1100						268
TH-3xCDF 8-14	5,5	2 1/2"	2 1/2"	1300	450	1500	1250	1220	430	680	130	A	313

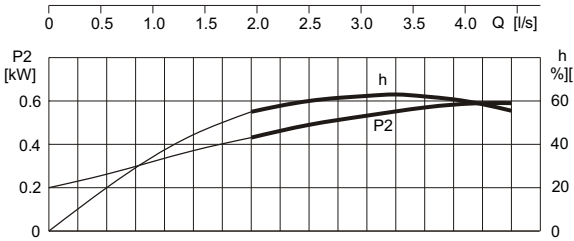
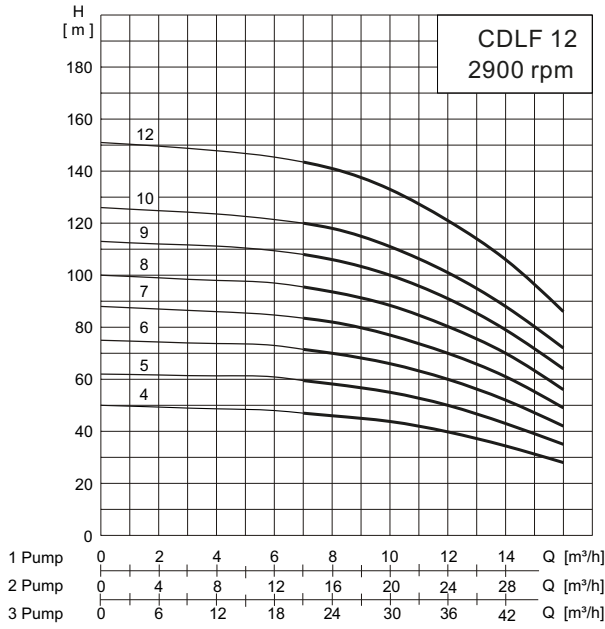

Pump Type	De	Db	Ba	Bb	Ba(max)	H	Ka	Kb	E	A	Tas.	w
TH-1xCDF 12-4	3	2"	2"	450	400	500	370	380	490	140	A	850
TH-1xCDF 12-5												900
TH-1xCDF 12-6												900
TH-1xCDF 12-7	5,5	2"	2"	450	400	500	370	380	490	140	A	1050
TH-1xCDF 12-8												1100
TH-1xCDF 12-9	7,5	2"	2"	450	400	500	370	380	490	140	A	1100
TH-1xCDF 12-10												1150
TH-1xCDF 12-12												1200

Pump Type	kW	De	Db	Ba	Bb	Ba(max)	H	Ka	Kb	E	A	Tas.	w
TH-2xCDF 12-4	3	2 1/2"	2 1/2"	920	450	1100	840	430	735	140	A	850	
TH-2xCDF 12-5												850	
TH-2xCDF 12-6	4	2 1/2"	2 1/2"	920	450	1100	840	430	735	140	A	900	
TH-2xCDF 12-7												900	
TH-2xCDF 12-8	5,5	2 1/2"	2 1/2"	920	450	1100	840	430	735	140	A	1050	
TH-2xCDF 12-9												1100	
TH-2xCDF 12-10	7,5	2 1/2"	2 1/2"	920	450	1100	840	430	735	140	A	1100	
TH-2xCDF 12-12												1200	

Pump Type	kW	De	Db	Ba	Bb	Ba(max)	H	Ka	Kb	E	A	Tas.	w
TH-3xCDF 12-4	3	3"	3"	1300	450	1500	1220	430	745	140	A	850	
TH-3xCDF 12-5												850	
TH-3xCDF 12-6	4	3"	3"	1300	450	1500	1220	430	745	140	A	900	
TH-3xCDF 12-7												900	
TH-3xCDF 12-8	5,5	3"	3"	1300	450	1500	1220	430	745	140	A	1050	
TH-3xCDF 12-9												1100	
TH-3xCDF 12-10	7,5	3"	3"	1300	450	1500	1220	430	745	140	A	1100	
TH-3xCDF 12-12												1200	

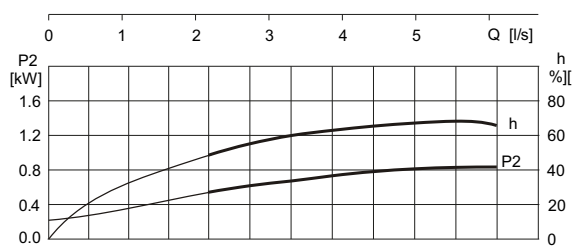
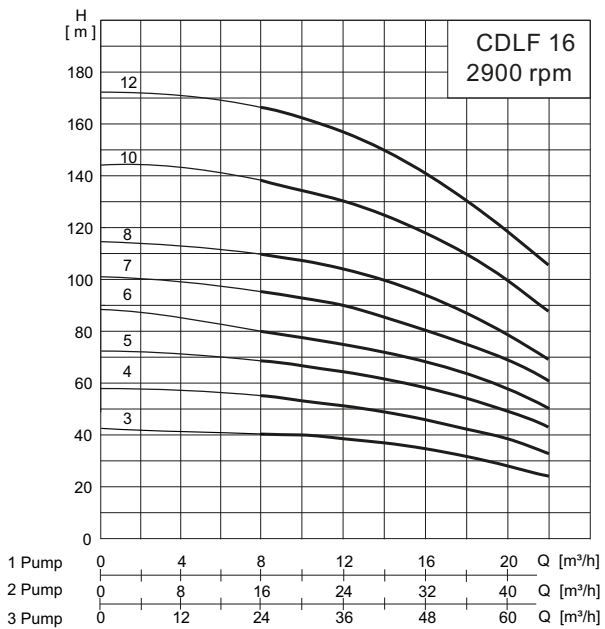

Pump Type	kW	De	Db	Ba	Bb	Ba(max)	H	Ka	Kb	E	A	Tas.	w
TH-1xCDF 16-3	3	2"	2"	450	400	500	370	380	490	140	A	850	
TH-1xCDF 16-4												900	
TH-1xCDF 16-5	5,5	2"	2"	450	400	500	370	380	490	140	A	1050	
TH-1xCDF 16-6												1100	
TH-1xCDF 16-7	7,5	2"	2"	450	400	500	370	380	490	140	A	1150	
TH-1xCDF 16-8												1200	
TH-1xCDF 16-10	11	2"	2"	570	490	-	1500	530	350	120	B	1600	
TH-1xCDF 16-12												1850	

Pump Type	kW	De	Db	Ba	Bb	Ba(max)	H	Ka	Kb	E	A	Tas.	w
TH-2xCDF 16-3	3	2 1/2"	2 1/2"	920	450	1100	840	430	735	140	A	850	
TH-2xCDF 16-4												900	
TH-2xCDF 16-5	5,5	2 1/2"	2 1/2"	920	450	1100	840	430	735	140	A	1050	
TH-2xCDF 16-6												1100	
TH-2xCDF 16-7	7,5	2 1/2"	2 1/2"	920	450	1100	840	430	735	140	A	1150	
TH-2xCDF 16-8												1200	
TH-2xCDF 16-10	11	2 1/2"	2 1/2"	700	780	-	1550	660	640	220	B	1650	
TH-2xCDF 16-12												382	

Pump Type	kW	De	Db	Ba	Bb	Ba(max)	H	Ka	Kb	E	A	Tas.	w
TH-3xCDF 16-3	3	3"	3"	1300	450	1500	1220	430	745	140	A	850	
TH-3xCDF 16-4												900	
TH-3xCDF 16-5	5,5	3"	3"	1300	450	1500	1220	430	745	140	A	1050	
TH-3xCDF 16-6												1100	
TH-3xCDF 16-7	7,5	3"	3"	1300	450	1500	1220	430	745	140	A	1150	
TH-3xCDF 16-8												1200	
TH-3xCDF 16-10	11	3"	3"	1150	800	-	1550	1110	660	220	B	1650	
TH-3xCDF 16-12												577	

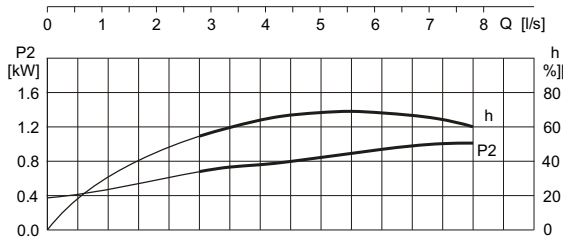
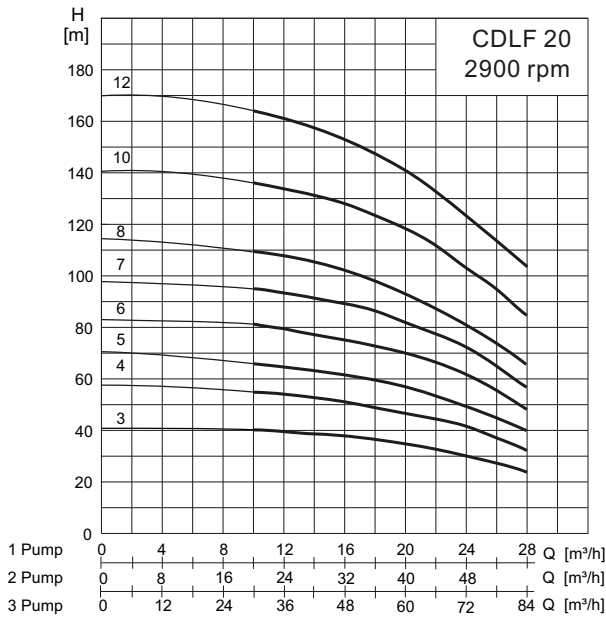

Performance curves are given according to ISO9906: 2012 Gr3B.

Pump Type	kW	De	Db	Ba	Bb	Ba(max)	H	Ka	Kb	E	A	Tas.	w
TH-1xCDLF 20-3	4	2 1/2"	2 1/2"	450	400	500	850	370	380	555	140	A	72
TH-1xCDLF 20-4	5,5						1000						88
TH-1xCDLF 20-5	7,5						1050						90
TH-1xCDLF 20-6	11						1100						96
TH-1xCDLF 20-7	15						1150						98
TH-1xCDLF 20-8	11			570	570	-	1450	530	430	220	B*	179	
TH-1xCDLF 20-10	1500						183						
TH-1xCDLF 20-12	1600						196						

Pump Type	kW	De	Db	Ba	Bb	Ba(max)	H	Ka	Kb	E	A	Tas.	w
TH-2xCDLF 20-3	4	3"	3"	920	450	1100	850	840	430	855	140	A	167
TH-2xCDLF 20-4	5,5						1000						199
TH-2xCDLF 20-5	7,5						1050						203
TH-2xCDLF 20-6	11						1100						215
TH-2xCDLF 20-7	15						1150						219
TH-2xCDLF 20-8	11			700	850	-	1450	660	710	220	B*	399	
TH-2xCDLF 20-10	1550						407						
TH-2xCDLF 20-12	1650						438						

Pump Type	kW	De	Db	Ba	Bb	Ba(max)	H	Ka	Kb	E	A	Tas.	w
TH-3xCDLF 20-3	4	4"	4"	1300	900	-	900	1260	760	855	220	B*	292
TH-3xCDLF 20-4	5,5						1100						340
TH-3xCDLF 20-5	7,5						1100						346
TH-3xCDLF 20-6	11						1150						364
TH-3xCDLF 20-7	15						1200						370
TH-3xCDLF 20-8	11			1400	597								
TH-3xCDLF 20-10	1500			609									
TH-3xCDLF 20-12	1600			653									

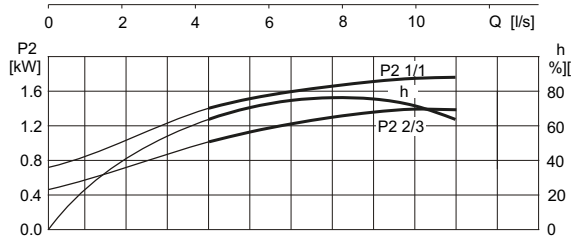
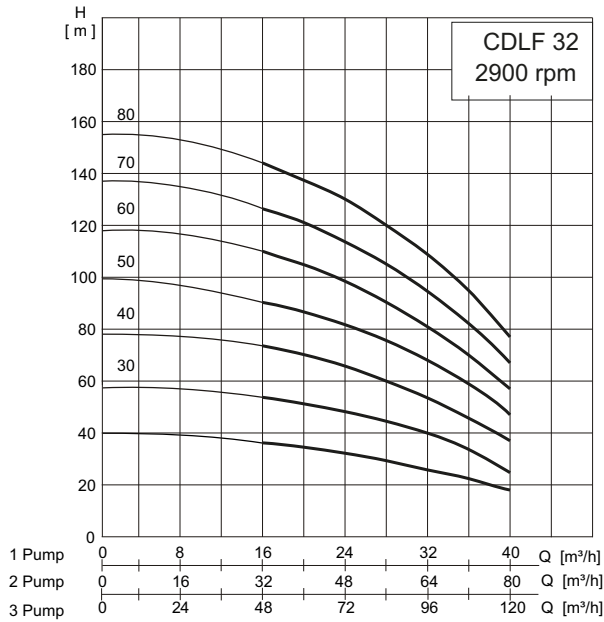

Pump Type	De	Db	Ba	Bb	H	Ka	Kb	E	A	Tas.	w	
TH-1xCDLF 32-20	4	2 1/2"	2 1/2"	570	610	1000	530	470	590	235	B	116
TH-1xCDLF 32-30	5,5					1150						131
TH-1xCDLF 32-40	7,5					1200						140
TH-1xCDLF 32-50	11					1550						241
TH-1xCDLF 32-60						1600						245
TH-1xCDLF 32-70						1650						264
TH-1xCDLF 32-80	15					1750						268

Pump Type	kW	De	Db	Ba	Bb	H	Ka	Kb	E	A	Tas.	w
TH-2xCDLF 32-20	4	4"	4"	850	930	1000	810	790	890	235	B	273
TH-2xCDLF 32-30	5,5					1150						303
TH-2xCDLF 32-40	7,5					1250						321
TH-2xCDLF 32-50	11					1550						482
TH-2xCDLF 32-60						1650						490
TH-2xCDLF 32-70						1700						518
TH-2xCDLF 32-80	15					1800						526

Pump Type	kW	De	Db	Ba	Bb	H	Ka	Kb	E	A	Tas.	w
TH-3xCDLF 32-20	4	5"	5"	1300	950	1000	1260	810	915	235	B	413
TH-3xCDLF 32-30	5,5					1150						458
TH-3xCDLF 32-40	7,5					1250						485
TH-3xCDLF 32-50	11					1550						721
TH-3xCDLF 32-60						1650						733
TH-3xCDLF 32-70						1700						780
TH-3xCDLF 32-80	15					1800						792

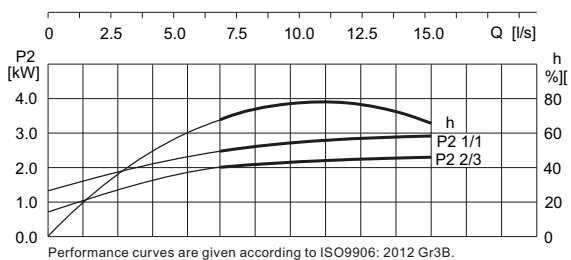
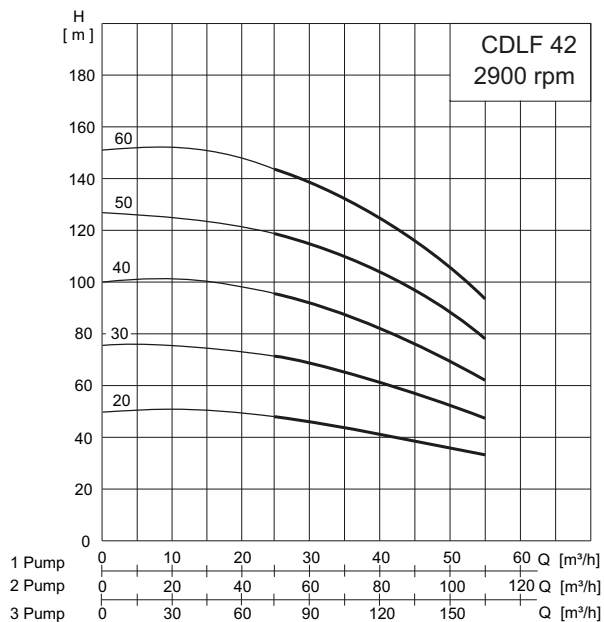

Pump Type	kW	De	Db	Ba	Bb	H	Ka	Kb	E	A	Tas.	w
TH-1xCDLF 42-20	7,5	3"	3"	570	570	1250	530	430	550	285	B	149
TH-1xCDLF 42-30	11					1450						222
TH-1xCDLF 42-40	15					1550						236
TH-1xCDLF 42-50	18,5					1700						260
TH-1xCDLF 42-60	22					1800						300

Pump Type	kW	De	Db	Ba	Bb	H	Ka	Kb	E	A	Tas.	w
TH-2xCDLF 42-20	7,5	4"	4"	850	1075	1250	810	935	1035	285	B	332
TH-2xCDLF 42-30	11					1500						493
TH-2xCDLF 42-40	15					1600						521
TH-2xCDLF 42-50	18,5					1750						569
TH-2xCDLF 42-60	22					1850						649

Pump Type	kW	De	Db	Ba	Bb	H	Ka	Kb	E	A	Tas.	w
TH-3xCDLF 42-20	7,5	5"	5"	1300	1100	1250	1260	960	1060	285	B	500
TH-3xCDLF 42-30	11					1500						739
TH-3xCDLF 42-40	15					1600						786
TH-3xCDLF 42-50	18,5					1750						858
TH-3xCDLF 42-60	22					1850						978

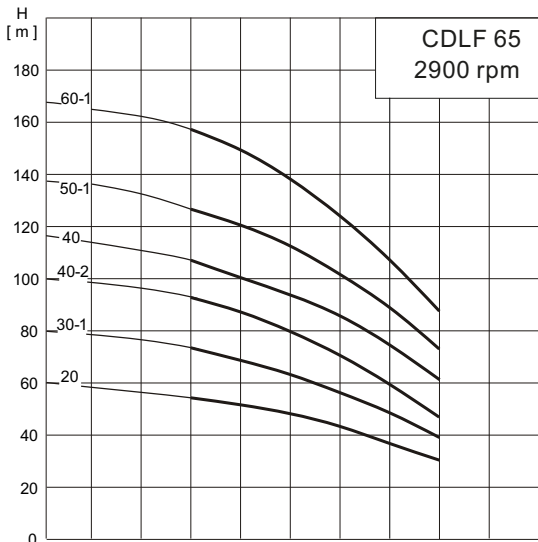

1 Pump 0 20 40 60 80 Q [m³/h]  
 2 Pump 0 40 80 120 160 Q [m³/h]  
 3 Pump 0 60 120 180 240 Q [m³/h]

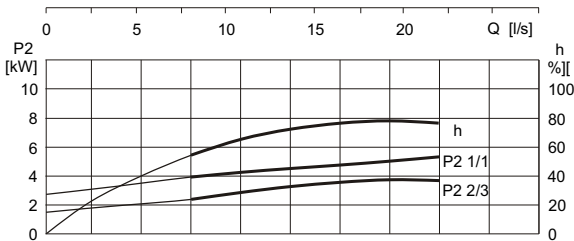

Performance curves are given according to ISO9906: 2012 Gr3B.

Pump Type	kW	De	Db	Ba	Bb	H	Ka	Kb	E	A	Tas.	w
TH-1xCDLF 65-20	11	4"	4"	570	600	1450	530	460	585	320	B	221
TH-1xCDLF 65-30-1	15					1550						236
TH-1xCDLF 65-40-2	18,5					1650						264
TH-1xCDLF 65-40	22					1700						297
TH-1xCDLF 65-50-1	30					1850						358
TH-1xCDLF 65-60-1	37					1950						388

Pump Type	kW	De	Db	Ba	Bb	H	Ka	Kb	E	A	Tas.	w
TH-2xCDLF 65-20	11	5"	5"	850	1150	1500	810	1010	1085	320	B	486
TH-2xCDLF 65-30-1	15					1550						531
TH-2xCDLF 65-40-2	18,5					1700						592
TH-2xCDLF 65-40	22					1750						663
TH-2xCDLF 65-50-1	30					1900						785
TH-2xCDLF 65-60-1	37					2000						850

Pump Type	kW	De	Db	Ba	Bb	H	Ka	Kb	E	A	Tas.	w
TH-3xCDLF 65-20	11	6"	6"	1300	1150	1500	1260	1010	1110	320	B	731
TH-3xCDLF 65-30-1	15					1550						796
TH-3xCDLF 65-40-2	18,5					1700						885
TH-3xCDLF 65-40	22					1750						984
TH-3xCDLF 65-50-1	30					1900						1167
TH-3xCDLF 65-60-1	37					2000						1262

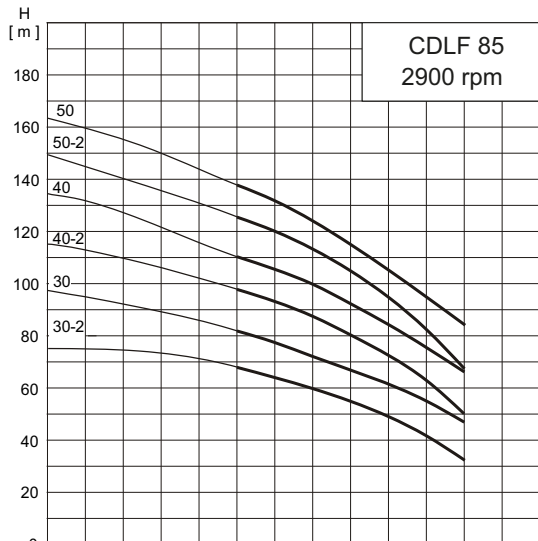

1 Pump 0 20 40 60 80 100 Q [m³/h]  
 2 Pump 0 40 80 120 160 200 Q [m³/h]  
 3 Pump 0 60 120 180 240 300 Q [m³/h]

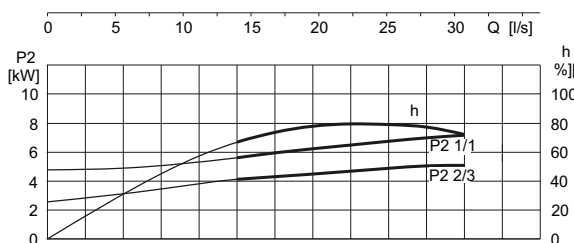

Performance curves are given according to ISO9906: 2012 Gr3B.

Pump Type	kW	De	Db	Ba	Bb	H	Ka	Kb	E	A	Tas.	w
TH-1xCDLF 85-30-2	18,5	4"	4"	570	600	1650	530	460	600	340	B	254
TH-1xCDLF 85-30	22					1700						291
TH-1xCDLF 85-40-2	30					1850						351
TH-1xCDLF 85-40	37					1850						351
TH-1xCDLF 85-50-2	37					1950						375
TH-1xCDLF 85-50	37					1950						375

Pump Type	kW	De	Db	Ba	Bb	H	Ka	Kb	E	A	Tas.	w
TH-2xCDLF 85-30-2	18,5	6"	6"	850	1150	1700	810	1010	1	340	B	562
TH-2xCDLF 85-30	22					1700						651
TH-2xCDLF 85-40-2	30					1900						776
TH-2xCDLF 85-40	37					1900						781
TH-2xCDLF 85-50-2	37					2000						829
TH-2xCDLF 85-50	37					2000						834

Pump Type	kW	De	Db	Ba	Bb	H	Ka	Kb	E	A	Tas.	w
TH-3xCDLF 85-30-2	18,5	8"	8"	1300	1250	1700	1260	1110	1	340	B	860
TH-3xCDLF 85-30	22					1700						991
TH-3xCDLF 85-40-2	30					1900						1176
TH-3xCDLF 85-40	37					1900						1176
TH-3xCDLF 85-50-2	37					2000						1248
TH-3xCDLF 85-50	37					2000						1253



Booster set with one pump

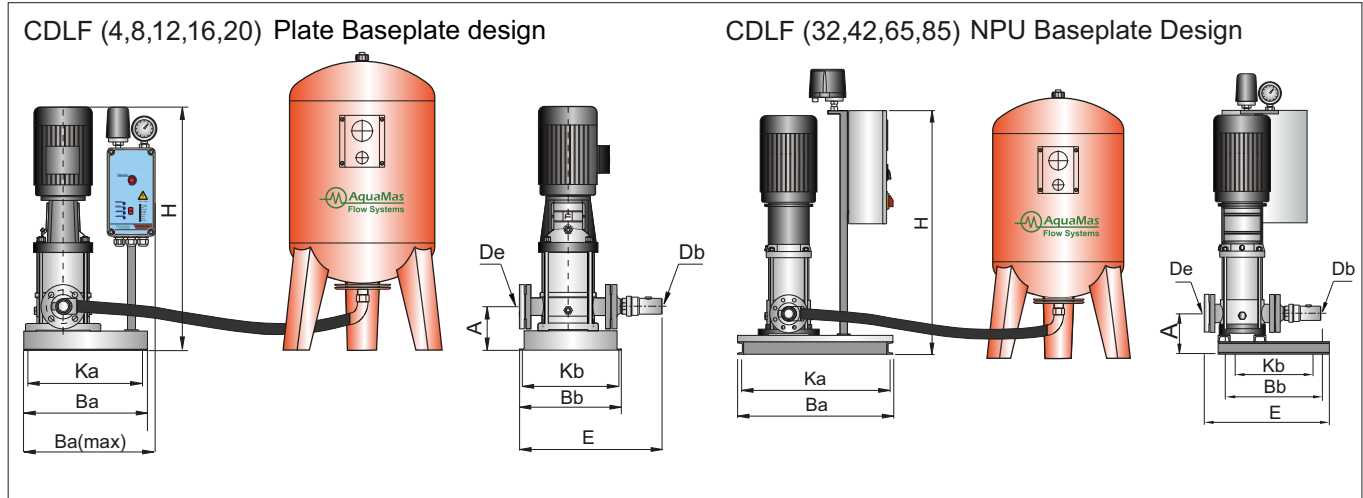

Booster set with two pump

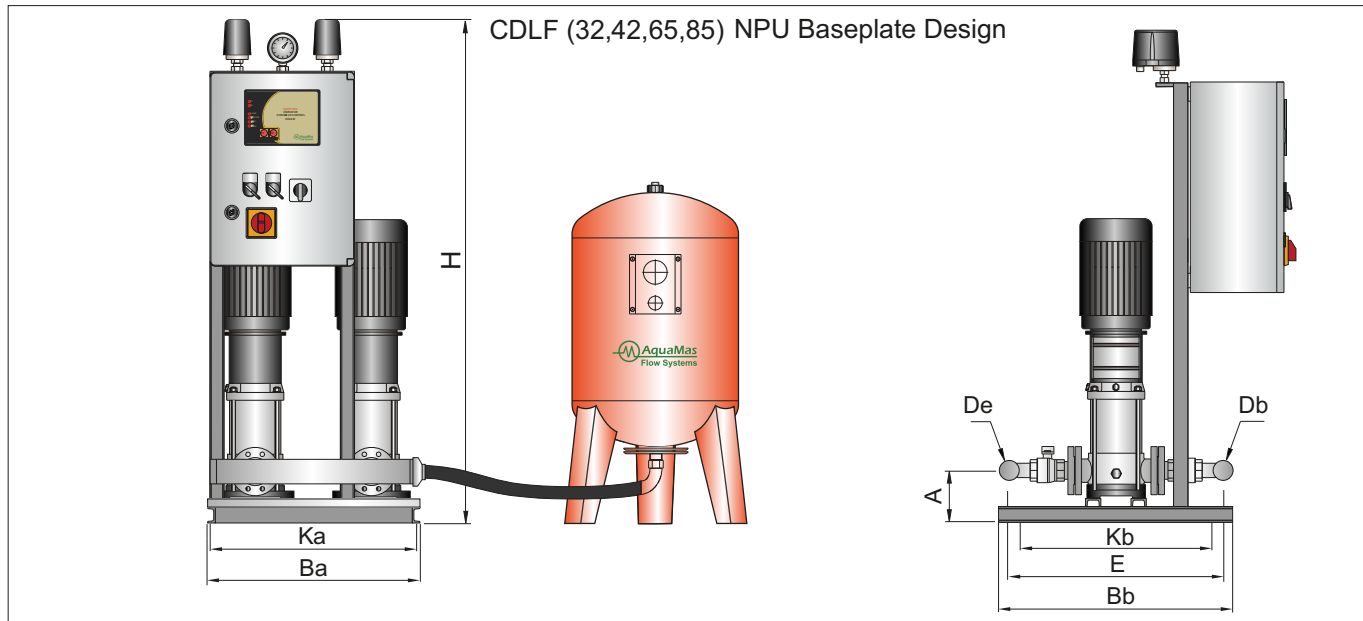

Booster set with three pump

