

SKM-E

MULTISTAGE CENTRIFUGAL PUMPS



Handled Liquids

Clean or slightly contaminated low viscosity liquids without solid & fibrous particles.

Technical Data

Discharge Flange — DN 40 ... DN 150 mm

Capacity — up to 400 m³/h

Head — up to 450 m

Speed — up to 2900 rpm

Operating Temperature — -10 °C up to +140 °C*

Casing Pressure (Pmax) – 30 bar (63 bar)*

(Pmax: Suction Pressure + Shutoff Head)

(*) The material of pumps differ according to the type of pumped liquid, operating temperature and pressure. Contact our company for detailed information.

Design Features

- Horizontal, multistage, end suction centrifugal pumps with closed impellers and diffusers
- 7 models from DN 40 to DN 150.

Pump Designation

Pump Type

Discharge Nozzle (DN-mm)

Number of Stages

SKM-E 100 / 6

- Suction nozzle flanges are according to EN 1092 - 2 / PN 16 and discharge nozzle flanges are according to EN 1092 - 2 / PN 40 (63).
(For steel or stainless steel casing pumps, flanges conform to related pressure class ratings defined in EN 1092 - 1)
- Discharge flange is on top for standard production, upon request different discharge flange positions can be applied.
- Axial thrust is balanced by back wear rings and balancing holes systems.
- All impellers are balanced statically and dynamically according to ISO 1940 class 6.3.
- Direction of rotation is always counter clockwise viewed from drive end. That's why these pumps can not be accoupled directly with diesel engines.
- Bearings of SKM-E type pumps are grease lubricated. Sleeve bearing used in the suction side is lubricated by the pumping liquid.

Shaft Sealing

- In standard production soft packing application is applied up to 110 C. Between 110 C and 140 C soft packing may also applied together with the stung box cooling.
- Pumps with mechanical seal can also be manufactured upon request.

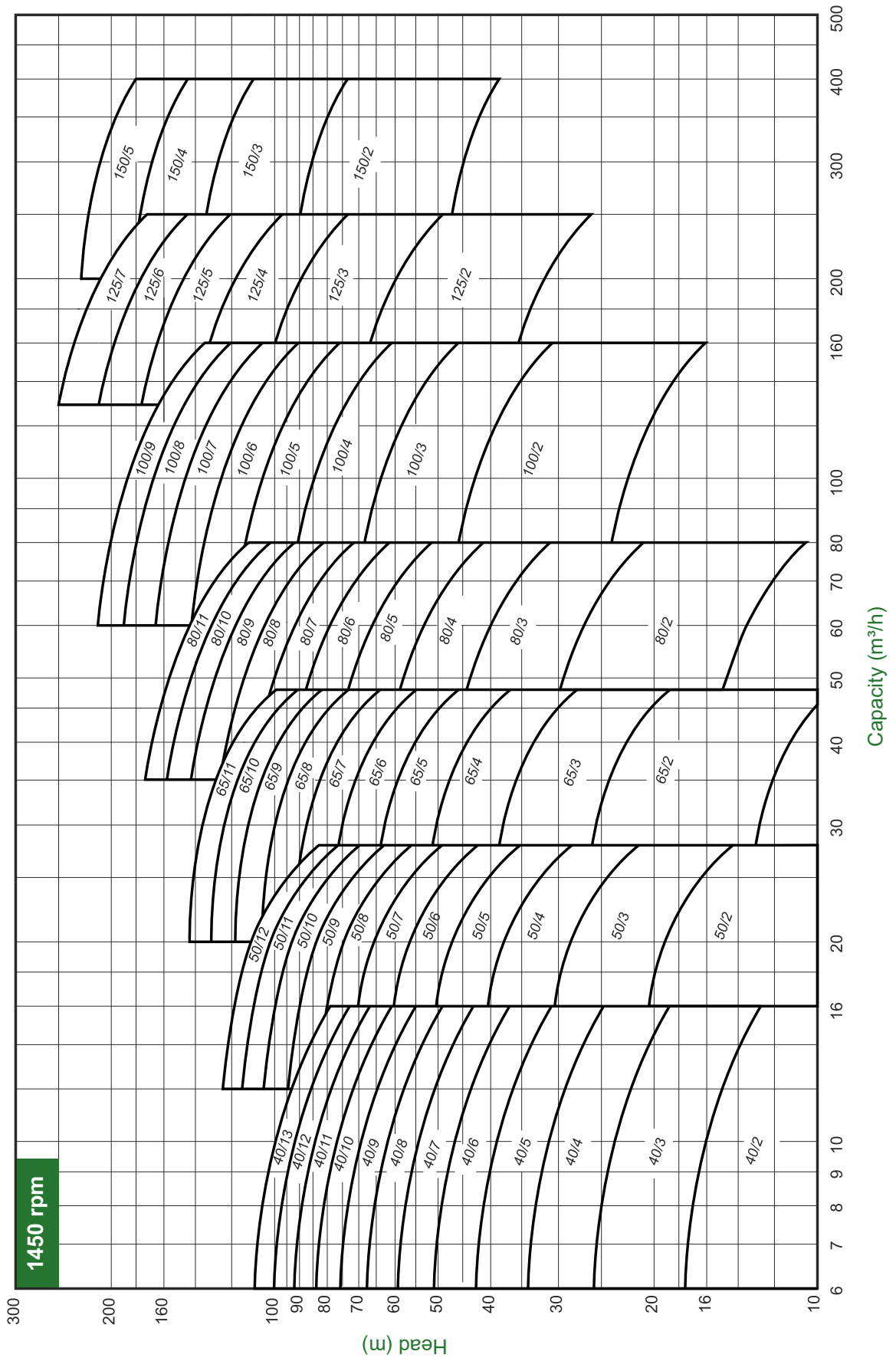

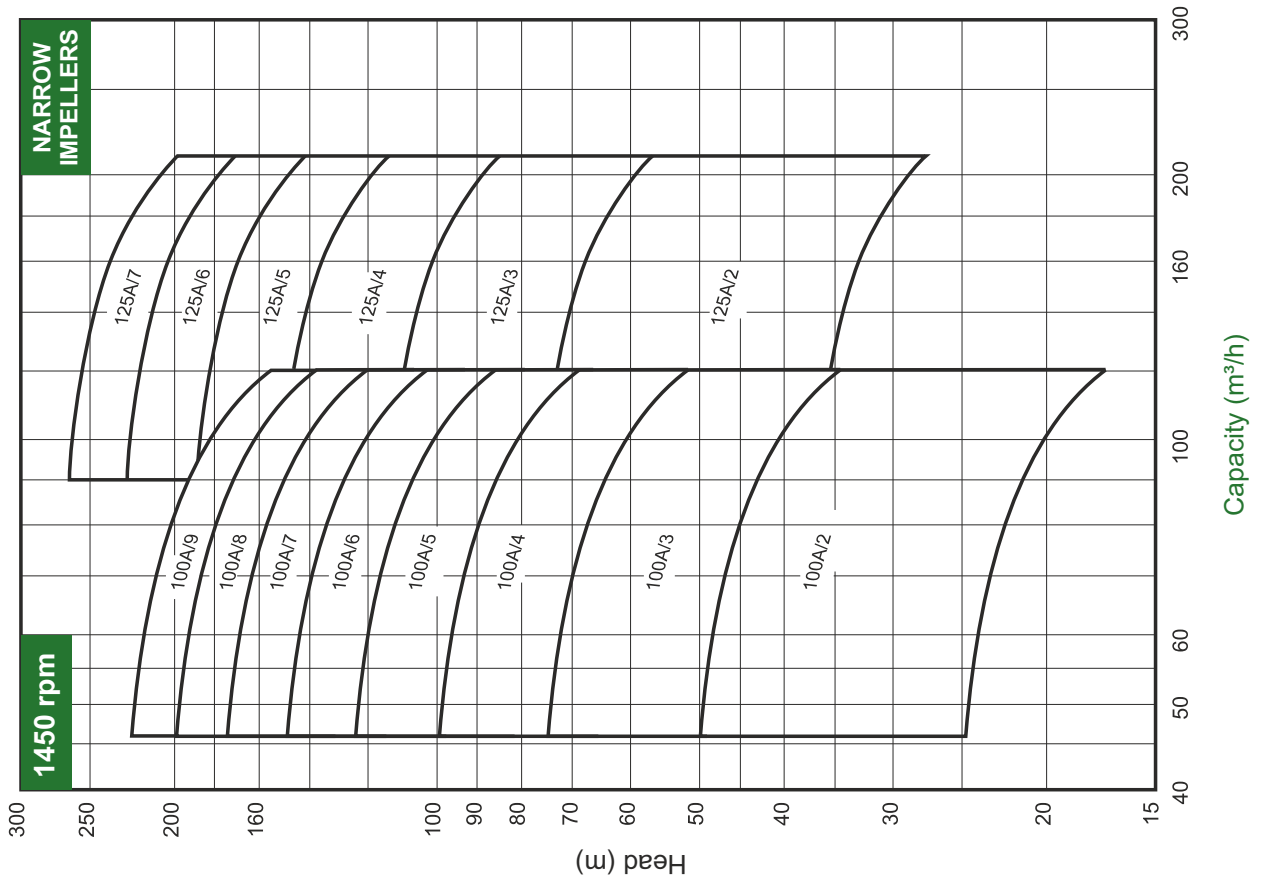
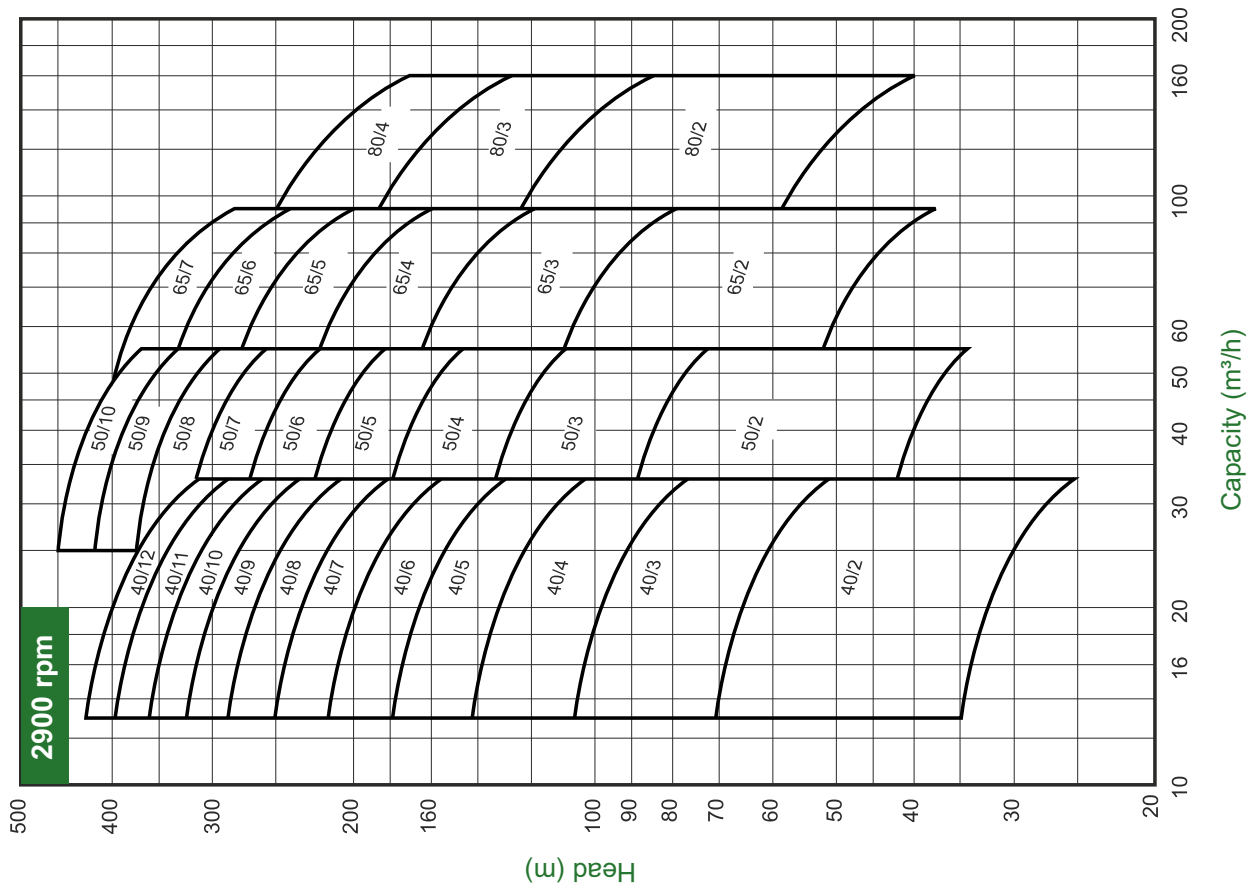

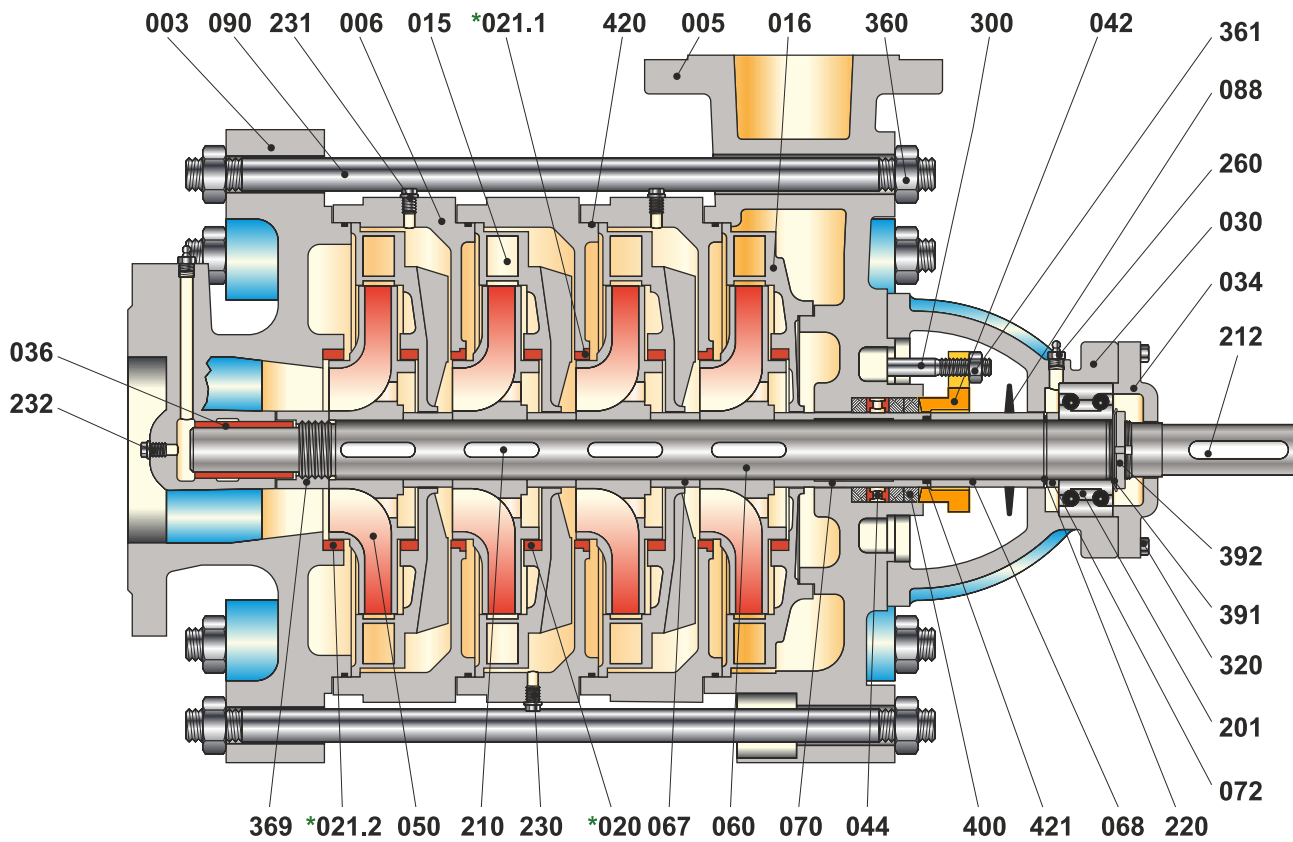

Parts List

Part No	Part Name	Part No	Part Name
003	Suction casing	090	Tiebolt
005	Discharge casing	201	Double row ball bearing
006	Stage casing	210	Impeller key
015	Diffuser	212	Coupling key
016	Final stage diffuser	220	Retaining ring
*020	Wear ring (Diffuser)	230	Drain plug
*021.1	Wear ring (Stage casing)	231	Filler plug
*021.2	Wear ring (Suction casing)	232	Blind plug
030	Bearing house	260	Grease nipple
034	Bearing end cover	300	Stuffing box stud
036	Bearing bush	320	Hex. head bolt
042	Stuffing box gland	360	Hex. nut
044	Latern ring	361	Hex. nut
*048	Mechanical seal cover	369	Shaft nut
050	Impeller	391	Safety washer
060	Shaft	392	Safety nut washer
067	Insterstage sleeve (Stage)	400	Soft packing
068	Spacer sleeve (Discharge side)	*405	Mechanical seal
070	Shaft sleeve (Soft packing)	420	O-Ring
072	Spacer sleeve (Bearing)	421	O-Ring
*074	Shaft Sleeve (Mechanical seal)	*422	O-Ring
088	Thrower		

* Optional

Mechanical Seal Application

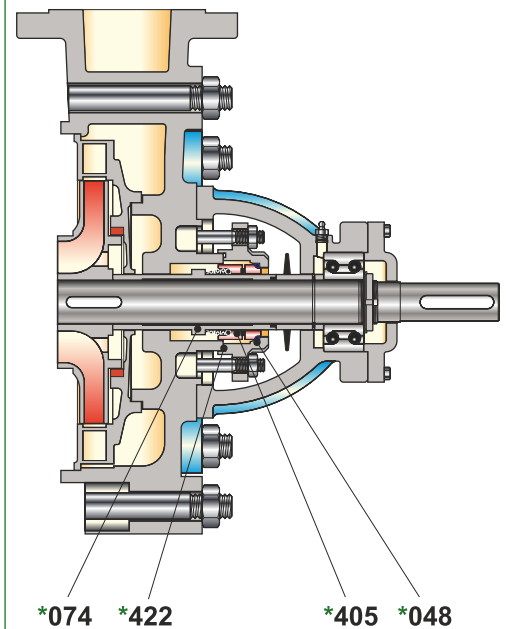

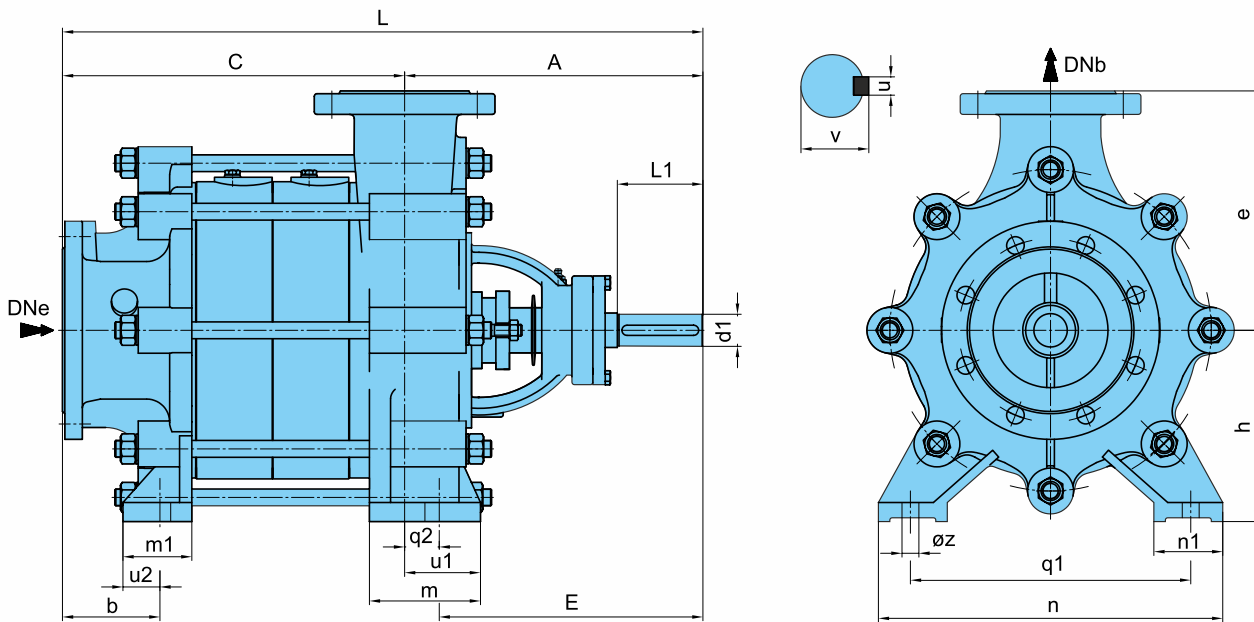

“C” according to the number of stages (mm)

Pump Type	2	3	4	5	6	7	8	9	10	11	12	13
40	187	242	297	352	407	462	517	572	627	682	737	792
50	212	274	336	398	460	522	584	646	708	770	832	
65	247	318	389	460	531	602	673	744	815	886		
80	280	363	446	529	612	695	778	861	944	1027		
100	347	447	547	647	747	847	947	1047				
125	364	479	594	709	824	939						
150	437	582	727	872								

Maximum no. of stages depending on shaft material

Pump Type	1.4462 / 1.4021		1.4301 / 1.4401	
	1450 rpm	2900 rpm	1450 rpm	2900 rpm
	1750 rpm	3500 rpm	1750 rpm	3500 rpm
40	13(13)	12(8)	13(13)	7(3)
50	12(12)	10(6)	12(10)	7(2)
65	11(11)	7(4)	11(8)	5(2)
80	11(11)	4(2)	11(8)	3(N/A)
100	9(7)	-	6(4)	-
125	7(5)	-	4(2)	-
150	5(3)	-	3(N/A)	-

Bearing Type

Pump Type	Bearing Type
40	6305
50	6306
65	6307
80	3308
100	3309
125	3310
150	3312

Pump Type	Dimensions (mm)																Shaft				Weight (kg)		
	DN _e	DN _b	A	b	L	E	e	h	m	m1	n	n1	q1	q2	øz	u1	u2	d1	l1	v	u	G	g
40	65	40	237	23	C+237	147	175	160	60	75	232	55	175	90	15	109	20	24	60	27	8	54	9,5
50	80	50	258	23	C+259	160	190	160	60	85	256	60	200	98	15	115	20	28	65	31	8	82	13
65	100	65	275	38	C+275	170	215	180	60	85	294	60	240	121	15	125	25	32	65	35	10	85	20
80	125	80	331	75	C+331	289	265	210	85	85	410	90	340	42	15	62	25	38	80	41	10	113	26
100	150	100	397	105	C+397	349	300	250	90	90	450	90	370	48	15	70	30	42	110	45	12	150	42
125	200	125	410	70	C+410	355	375	300	110	112	572	105	450	55	23	80	30	48	110	51,5	14	264	75
150	200	150	475	60	C+475	410	425	350	130	135	655	110	550	65	23	103	30	55	110	59	16	455	120

Note: Right reserved to change without notice.

Pump weight = G + (s x g) (s: number of stages)

Flange Dimensions

EN 1092 -2	DN _e /DN _b	Suction & Discharge (PN 16)				Suction & Discharge (PN 40)			
		Df	k	s	n	Df	k	s	n
	40	150	110	19	4	150	110	19	4
50	165	125	19	4	165	125	19	4	
65	185	145	19	4	185	145	19	8	
80	200	160	19	8	200	160	19	8	
100	220	180	19	8	235	190	23	8	
125	250	210	19	8	270	220	28	8	
150	285	240	23	8	300	250	28	8	
200	340	295	23	12	375	320	31	12	

“ n “ number of holes

The diagram shows a side view of the flange with dimensions Df (total height), k (flange thickness), and DN_e/DN_b (flange diameter). The front view shows a circular flange with a central hole and 'n' holes around the perimeter, with 's' representing the hole spacing.

Material Options

	0.6025	0.7040	0.7043	1.0619	1.4308	1.4309	1.4408	1.4409	1.4500	1.4517	1.4469	1.4317	1.4008	2.1050.01	2.0975.01	2.1096.01	1.0503	1.4021	1.4021+QT	1.4301	1.4404	1.4460	1.4462	Tungsten Carbide	
Suction Casing	●	○	○		○	○	○	○	○	○	○	○	○	○											
Discharge Casing	●	○	○		○	○	○	○	○	○	○	○	○	○											
Stage Casing	●	○	○		○	○	○	○	○	○	○	○	○	○											
Diuser	●	○	○	○	○	○	○	○	○	○	○	○	○	○	○	○									
Impeller	●	○	○	○	○	○	○	○	○	○	○	○	○	○	○	○						○			
Shaft																		●	○	○	○		○		
Bearing Housing	●	○	○	○	○	○	○	○																	
Wear Ring	○	○	○	○	○	○	○	○	○	○	○	○	○	○	○	○									
Spacer Sleeve																	●	○	○	○	○		○		
Shaft Sleeve																	●	○	○	○	○		○		
Interstage Sleeve																	●	○	○	○	○		○		
Sleeve Bearing														●										○	
Mechanical Seal (*)	EN 12756																								

(*) Optional: Depending on customer requirement or request, different types and brands of mechanical seals are applicable. ● Standard manufacturing ○ Optional

Material Equivalents

Description	DIN / EN	AISI / SAE / ASTM	
Cast Iron	0.6025	EN-GJL-250 (GG25)	A48 Class 40B
Nodular Cast Iron	0.7040	EN-GJS-400-15 (GGG40)	A536 60-40-18
Nodular Cast Iron	0.7043	EN-GJS-400-18-LT (GGG40.3)	A536 60-40-18
Cast Steel	1.0619	GP240GHGS-C25	A216 WCB
Chrome Nickel Cast Steel	1.4308	GX5CrNi19-10	A351 CF8
Chrome Nickel Cast Steel (low carbon)	1.4309	GX2CrNi19-11	A351 CF3
Chrome Nickel Molybdenum Cast Steel	1.4408	GX5CrNiMo19-11-2	A351 CF8M
Chrome Nickel Molybdenum Cast Steel (low carbon)	1.4409	GX2CrNiMo19-11-2	A351 CF3M
Austenitic Cast Steel	1.4500	GX7NiCrMoCuNb25-20	A351 CN7M
Austenitic - Ferritic Cast Steel (duplex)	1.4517	GX2CrNiMoCuN25-6-3-3	A890 CD4MCuN
Austenitic - Ferritic Cast Steel (super duplex)	1.4469	GX2CrNiMoN26-7-4	A890 CE3MN
Martenzitic Stainless Cast Steel	1.4317	GX4CrNi13-4	A352 CA6NM
Martenzitic Stainless Cast Steel	1.4008	GX7CrNiMo12-1	A217 CA15
Cast Bronze (tin alloy)	2.1050.01	G-CuSn10	B427 C90700
Cast Bronze (nickel alloy)	2.0975.01	G-CuAl10Ni	B148 C95500
Cast Bronze (lead)	2.1096.01	G-CuSn5ZnPb	B584 C83600
Carbon Steel	1.0503	C45	AISI 1045
Chrome Steel	1.4021	X20Cr13	A276 Type 420
Chrome Steel (heat treated)	1.4021	X20Cr13	A276 Type 420+QT
Chrome Nickel Steel	1.4301	X5CrNi18-10	A276 Type 304
Chrome Nickel Steel (low carbon)	1.4404	X2CrNiMo17-12-2	A276 Type 316L
Duplex (austenitic-ferritic) Steel	1.4460	X3CrNiMoN27-5-2	AISI 329
Duplex (austenitic-ferritic) Steel	1.4462	X2CrNiMoN22-5-3	UNS S32205

Flange Positions

Counter clockwise rotation viewed from driver (Discharge flange is on the motor side)

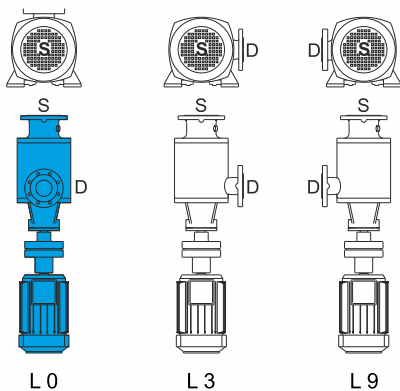

Explanation

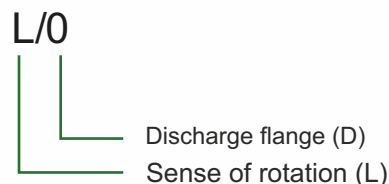

Sense of rotation viewed from driver

L : Left