

PC - V

WASTE WATER AND PROCESS PUMPS
(SUMP DESIGN)



Handled Liquids

Domestic and industrial waste water, raw sewage, viscous and corrosive liquids, liquids with fibrous and solid substances.

Technical Data

Discharge Flange _____ DN 40...DN 300 mm

Capacity _____ up to 1600 m³/h

Head _____ up to 95 m

Speed _____ up to 1450 rpm

Operating Temperature _____ up to +95 °C

Casing Pressure (P_{max}) _____ 10 bar

Design Features

- Vertical, wide volute casing, single stage, end suction, centrifugal pumps with enclosed, semi-open or vortex type impeller.
- Up to 4 m. column length.
- Discharge pipe is extended up to base plate for easy installation.
- Closed, semi-open or free vortex type impeller design.
- Discharge flanges conform to EN 1092-2 / PN 10. (EN 1092-1 / PN 10 for steel or stainless steel casing)

Pump Designation

PC-V 250 - 315 AB

Pump Type _____

Discharge Nozzle (DN-mm) _____

Nominal Impeller Diameter (mm) _____

Impeller Type _____

- All impellers are dynamically or statically balanced according to ISO 1940 Class 6.3.
- Axial thrust is balanced by impeller back ribs.
- Direction of rotation is clockwise viewed from drive end.
- Bearings of PC-V type pumps are grease lubricated. Bottom and internal sleeve bearings are lubricated by the pumping liquid. (different lubrication systems can be applied for the sleeve bearings in case of request or requirement. Contact for detailed information)

Shaft Sealing

- No sealing is required.

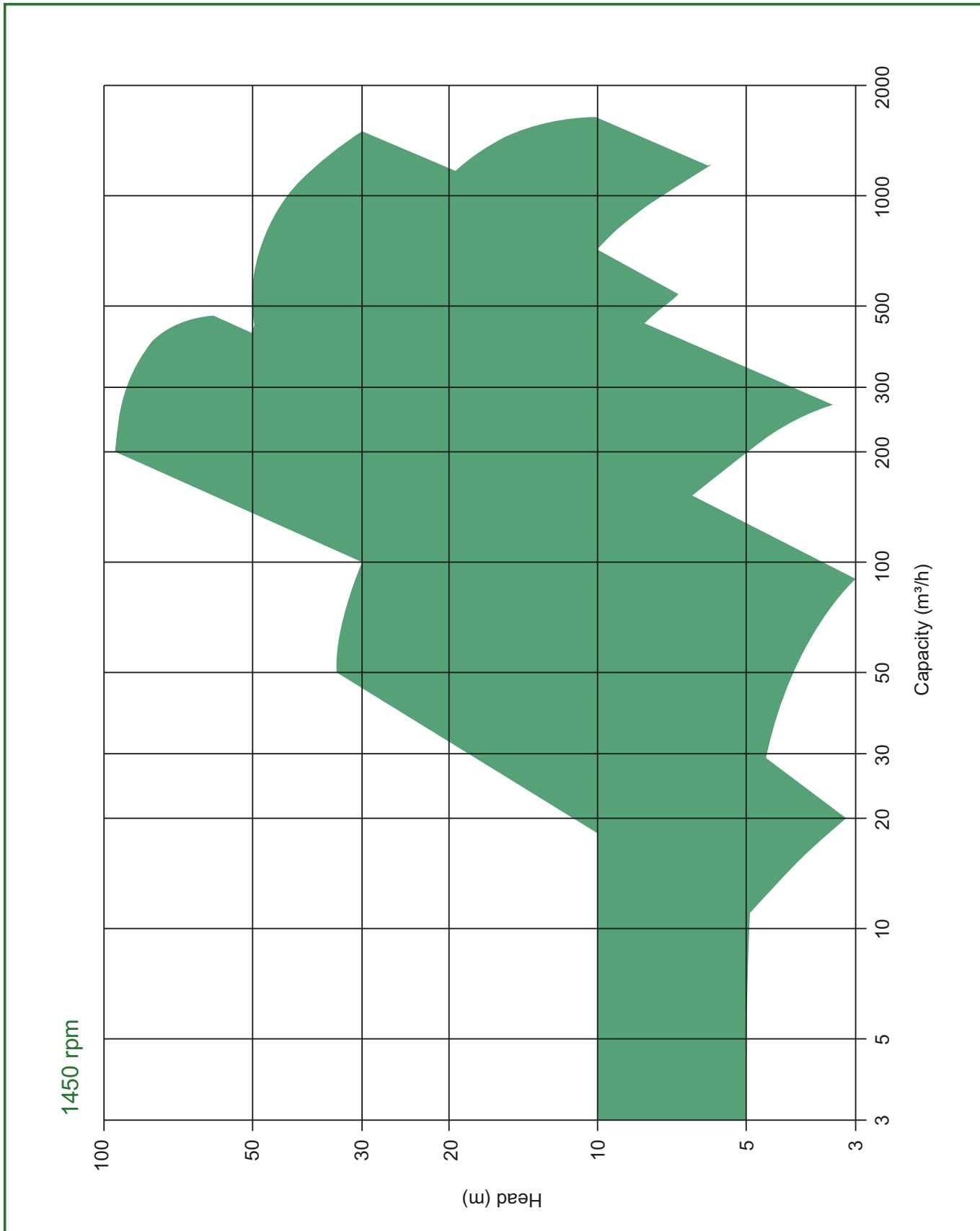

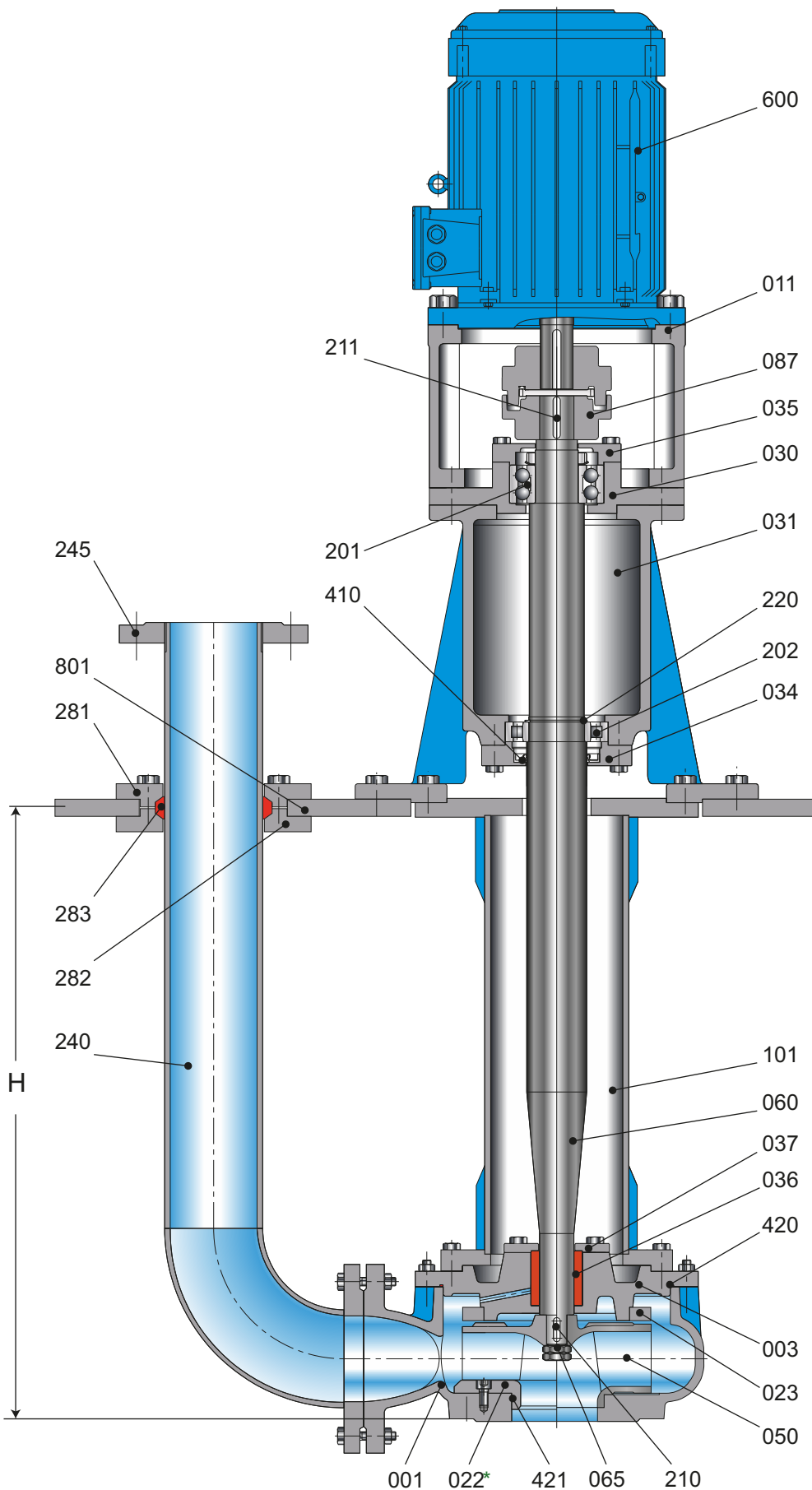

Part List

001	Volute Casing
003	Casing Cover
011	Motor Pedestal
023	Back Wear Plate
*022	Front Wear Ring
030	Bearing Housing (top)
031	Bearing Housing (bottom)
034	Bearing Cover (bottom)
035	Bearing Cover (top)
036	Sleeve Bearing
037	Sleeve Bearing Cover
050	Impeller
060	Shaft
065	Impeller Nut
087	Flexible Coupling
101	Column Pipe
201	Double Row Ball Bearing
202	Cylindrical Roller Bearing
210	Impeller Key
211	Coupling Key
220	Circlip
240	Discharge Pipe
245	Discharge Flange
281	Top Fixing Flange
282	Bottom Fixing Flange
283	Rubber Gasket
410	Oil Seal
420	O-Ring
421	O-Ring
600	Electric Motor
801	Base Plate

(*) Optional

PART LIST	0.6025	0.7040	1.0619	1.4308	1.4309	1.4408	1.4409	1.4500	1.4517	1.4469	1.4317	1.4008	2.1050.01	2.0975.01	2.1096.01	1.0037	1.0503	1.4021	1.4021+QT	1.4301	1.4404	1.4460	1.4462	Tungsten Carbide	
Volute Casing	●	○	○	○	○	○	○	○	○	○	○	○	○												
Casing Cover	●	○	○	○	○	○	○	○	○	○	○	○	○												
Impeller	●	○	○	○	○	○	○	○	○	○	○	○	○	○	○								○		
Shaft																	●	○	○	○	○		○		
Bearing Housing	●	○	○	○	○	○	○																		
Column Pipe																●				○	○				
Front Wear Plate	○	○	○	○	○	○	○	○	○	○	○	○	○	○	○										
Back Wear Plate	●	○	○	○	○	○	○	○	○	○	○	○	○	○	○										
Sleeve Bearing													●											○	

● Standard manufacturing
○ Optional

Material Equivalents

Description	DIN / EN	AISI / SAE / ASTM	
Cast Iron	0.6025	EN-GJL-250 (GG25)	A48 Class 40B
Nodular Cast Iron	0.7040	EN-GJS-400-15 (GGG40)	A536 60-40-18
Nodular Cast Iron	0.7043	EN-GJS-400-18-LT (GGG40.3)	A536 60-40-18
Cast Steel	1.0619	GP240GHGS-C25	A216 WCB
Chrome Nickel Cast Steel	1.4308	GX5CrNi19-10	A351 CF8
Chrome Nickel Cast Steel (low carbon)	1.4309	GX2CrNi19-11	A351 CF3
Chrome Nickel Molybdenum Cast Steel	1.4408	GX5CrNiMo19-11-2	A351 CF8M
Chrome Nickel Molybdenum Cast Steel (low carbon)	1.4409	GX2CrNiMo19-11-2	A351 CF3M
Austenitic Cast Steel	1.4500	GX7NiCrMoCuNb25-20	A351 CN7M
Austenitic - Ferritic Cast Steel (duplex)	1.4517	GX2CrNiMoCuN25-6-3-3	A890 CD4MCuN
Austenitic - Ferritic Cast Steel (super duplex)	1.4469	GX2CrNiMoN26-7-4	A890 CE3MN
Martenzitic Stainless Cast Steel	1.4317	GX4CrNi13-4	A352 CA6NM
Martenzitic Stainless Cast Steel	1.4008	GX7CrNiMo12-1	A217 CA15
Cast Bronze (tin alloy)	2.1050.01	G-CuSn10	B427 C90700
Cast Bronze (nickel alloy)	2.0975.01	G-CuAl10Ni	B148 C95500
Cast Bronze (lead)	2.1096.01	G-CuSn5ZnPb	B584 C83600
Steel	1.0037	St37	A 29 1015
Carbon Steel	1.0503	C45	AISI 1045
Chrome Steel	1.4021	X20Cr13	A276 Type 420
Chrome Steel (heat treated)	1.4021	X20Cr13	A276 Type 420+QT
Chrome Nickel Steel	1.4301	X5CrNi18-10	A276 Type 304
Chrome Nickel Steel (low carbon)	1.4404	X2CrNiMo17-12-2	A276 Type 316L
Duplex (austenitic-ferritic) Steel	1.4460	X3CrNiMoN27-5-2	AISI 329
Duplex (austenitic-ferritic) Steel	1.4462	X2CrNiMoN22-5-3	UNS S32205

Flange Dimensions

DNe/DNb	Suction & Discharge (PN 10)			
	Df	k	s	n
40	150	110	19	4
50	165	125	19	4
65	185	145	19	4
80	200	160	19	8
100	220	180	19	8
125	250	210	19	8
150	285	240	23	8
200	340	295	23	8
250	395	350	23	12
300	445	400	23	12

"n" number of holes